

Coaxial Switch

NON-CATALOG

ZYSWA-2-50DR

50Ω SPDT, TTL Driver, Absorptive DC² to 5 GHz



CASE STYLE: ZZ121

Connectors Model
SMA ZYSWA-2-50DR
BRACKET (OPTION "B")

Maximum Ratings

Operating Temperature	-20°C to 85°C
Storage Temperature	-55°C to 100°C
Input Power	+20dBm
Permanent damage may occur if any of these limits are exceeded.	

Coaxial/Pin Connections

RF IN	3
RF OUT 1	2
RF OUT 2	1
TTL IN	4
+5V	+5VDC
-5V	-5VDC

Features

- wideband, DC to 5 GHz
- fast rise/fall time, 6ns typ.
- low video break thru, 30 mV P-P typ.

Applications

- antenna switching
- instrumentation
- cellular/PCN
- transmitters/receivers
- satellite communications

Electrical Specifications

FREQ. ² (GHz)	INSERTION LOSS (dB)						1dB COMPR. (dBm)						IN-OUT ISOLATION (dB)						
	DC-500 MHz		500-2000 MHz		2000-5000 MHz		DC-500 MHz		500-2000 MHz		2000-5000 MHz		DC-500 MHz		500-2000 MHz		2000-5000 MHz		
f _L	f _U	T _{yp.}	Max.	T _{yp.}	Max.	T _{yp.}	Max.	T _{yp.}	Min.	T _{yp.}	Min.	T _{yp.}	Min.	T _{yp.}	Min.	T _{yp.}	Min.		
DC	5	1.1	1.5	1.4	1.9	1.9	—	18	13	20	17	22.5	20	42	38	31	27	20	19

Outline Drawing

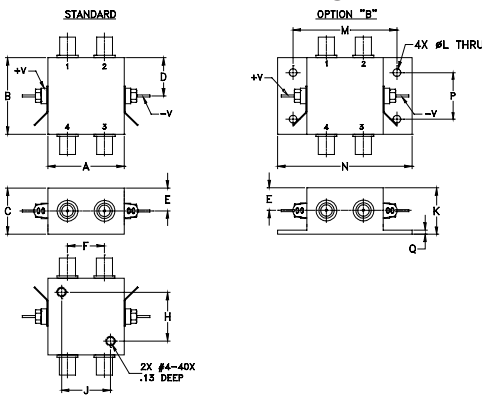

Outline Dimensions (inch/mm)

A	B	C	D	E	F	G	
1.25	1.25	0.75	0.63	0.38	0.61	--	0.1
31.75	31.75	19.05	16.00	9.65	15.49	--	2.54
J	K	L	M	N	P	Q	grd
0.800	0.76	0.125	1.688	2.18	0.75	0.07	
20.32	19.30	3.18	42.88	55.37	19.05	1.78	

Additional Specifications			
Control Voltage	0/5.5, max.	VSWR:(1)	1.4 typ., 2.0 max. DC to 3 GHz
Low Threshold, max.	0.8	Rise/Fall time (10%-90%), ns Switching time, 50% of Control to 90% RF (Turn-on), ns 10% RF (Turn-off), ns	2.5 max. 3 to 5 GHz
High Threshold, min.	2.0		6 typ., 12 max.
Control Current, mA	High V: 2 typ., 5 max. Low V: 0.2 max.		20 typ., 40 max.
Positive Supply, V	+5+0.5/-0.1	**Video Leakage, mVp-p 0/-5V Control	30 typ.
Negative Supply, V	-5-0.5/+0.1		
Positive Supply Current, mA	20 max.		
Negative Supply Current, mA	20 max.		

Control Port	RF outputs	
	1	2
Low	On	Off
High	Off	On

1. OFF state at RF output is low impedance
 ** Video leakage or break through is defined as leakage of TTL switching signal to RF output ports.
 2. All RF connections must be DC blocked or held at 0V DC

Electrical Schematic

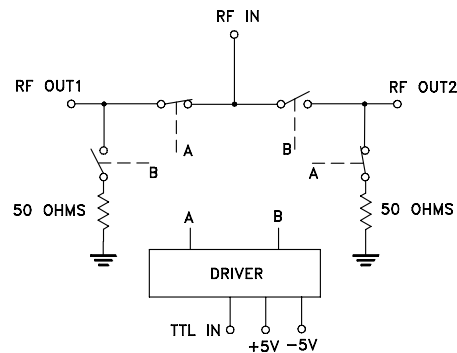

Notes

- A. Performance and quality attributes and conditions not expressly stated in this specification document are intended to be excluded and do not form a part of this specification document.
 B. Electrical specifications and performance data contained in this specification document are based on Mini-Circuit's applicable established test performance criteria and measurement instructions.
 C. The parts covered by this specification document are subject to Mini-Circuits standard limited warranty and terms and conditions (collectively, "Standard Terms"); Purchasers of this part are entitled to the rights and benefits contained therein. For a full statement of the Standard Terms and the exclusive rights and remedies thereunder, please visit Mini-Circuits' website at www.minicircuits.com/MCLStore/terms.jsp



Typical Performance Data

FREQ. (MHz)	ON				INSERTION LOSS (dB)				OFF				ISOLATION (dB)			VSWR		
	TTL Low @ 0V		IN-OUT 1		AMP. UNBAL.				TTL High @ 5V		IN-OUT 1		DELTA		IN	OUT		
	\bar{x}	σ	\bar{x}	σ	\bar{x}	σ	\bar{x}	σ	\bar{x}	σ	\bar{x}	σ	\bar{x}	σ	\bar{x}	\bar{x}	\bar{x}	
3.00	0.84	0.01	0.01	0.01	0.01	0.01	0.01	65.32	0.46	0.44	0.35	1.16	1.16	1.17				
5.00	0.83	0.01	0.01	0.01	0.01	0.01	0.01	65.59	1.00	0.97	0.43	1.17	1.16	1.17				
10.00	0.83	0.02	0.01	0.01	0.01	0.01	0.01	65.42	0.63	0.56	0.20	1.17	1.16	1.17				
20.00	0.89	0.04	0.02	0.02	0.02	0.02	0.02	66.30	0.68	0.76	0.63	1.17	1.16	1.17				
50.00	0.85	0.01	0.01	0.01	0.01	0.01	0.01	65.63	1.12	1.37	0.50	1.17	1.16	1.18				
100.00	0.87	0.02	0.01	0.01	0.01	0.01	0.01	61.02	0.81	1.22	1.06	1.17	1.16	1.18				
200.00	0.89	0.02	0.01	0.01	0.01	0.01	0.01	53.60	0.42	0.37	0.32	1.18	1.16	1.18				
500.00	0.95	0.02	0.00	0.01	0.01	0.01	0.01	43.89	0.27	0.52	0.15	1.22	1.16	1.20				
1000.00	1.05	0.02	0.01	0.01	0.01	0.01	0.01	37.39	0.23	0.62	0.12	1.28	1.15	1.23				
1150.64	1.05	0.02	0.01	0.01	0.01	0.01	0.01	36.05	0.25	0.62	0.11	1.29	1.15	1.24				
1724.45	1.22	0.02	0.04	0.02	0.02	0.02	0.02	32.34	0.30	0.73	0.08	1.29	1.14	1.26				
2000.00	1.13	0.01	0.01	0.01	0.01	0.01	0.01	30.92	0.28	0.76	0.06	1.27	1.13	1.25				
2441.73	1.17	0.01	0.01	0.01	0.01	0.01	0.01	29.06	0.27	0.69	0.11	1.22	1.15	1.22				
2561.27	1.25	0.03	0.02	0.01	0.01	0.01	0.01	28.66	0.27	0.62	0.15	1.20	1.15	1.22				
3135.09	1.42	0.05	0.06	0.00	0.00	0.00	0.00	26.96	0.30	0.23	0.14	1.11	1.21	1.10				
3708.91	1.48	0.04	0.06	0.02	0.02	0.02	0.02	25.86	0.28	0.33	0.18	1.14	1.27	1.16				
4282.73	1.58	0.06	0.12	0.04	0.04	0.04	0.04	25.02	0.36	0.41	0.23	1.23	1.33	1.24				
4713.09	1.73	0.05	0.02	0.01	0.01	0.01	0.01	24.78	0.31	0.62	0.26	1.21	1.33	1.24				
4856.55	1.80	0.05	0.03	0.02	0.02	0.02	0.02	24.69	0.32	0.65	0.26	1.18	1.34	1.25				
5000.00	1.80	0.06	0.04	0.02	0.02	0.02	0.02	24.46	0.30	0.58	0.26	1.15	1.34	1.26				

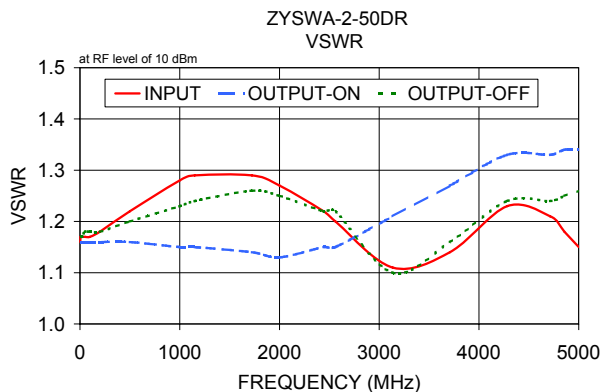
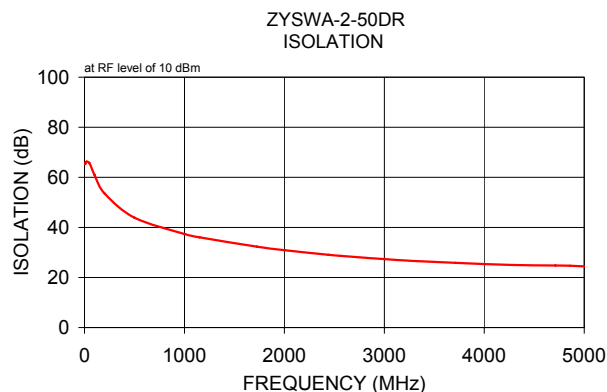
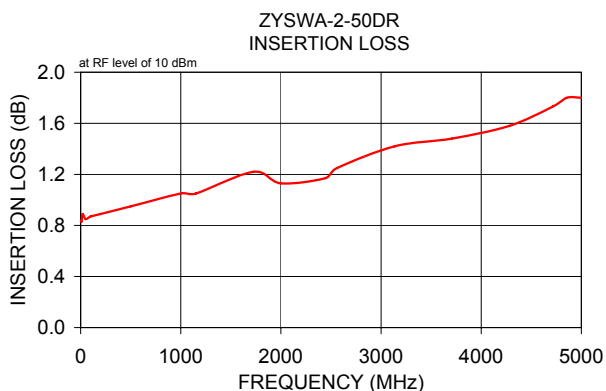

Notes

- Performance and quality attributes and conditions not expressly stated in this specification document are intended to be excluded and do not form a part of this specification document.
- Electrical specifications and performance data contained in this specification document are based on Mini-Circuit's applicable established test performance criteria and measurement instructions.
- The parts covered by this specification document are subject to Mini-Circuits standard limited warranty and terms and conditions (collectively, "Standard Terms"); Purchasers of this part are entitled to the rights and benefits contained therein. For a full statement of the Standard Terms and the exclusive rights and remedies thereunder, please visit Mini-Circuits' website at www.minicircuits.com/MCLStore/terms.jsp

